

REAR-MOUNTED BOOM MOWER SPECIFICATIONS

MODELS: RMB1445-1 | RMB1660-1 | RMB1865-1 | PT5 Powertrim-2

Minimum Tractor PTO HP/Weight	See Head Selection Chart - Varies Based on Head Choice			
Tractor PTO	540	540	540	NA
Machine Weight with Flail	1,220 lb.	2,403 lb.	2,470 lb.	415 lb.
Hydraulic System	Totally Independent			Open Center Hyd. System (Closed Center Kit Avail.), Tractor Remote Outlet, 3.7-5.6 GPM, Flow Control Valve Kit Std
Attachment Method	Cat 1/2, 3-Point Mount			Cat 1/2, 3-Point Mount
Controls	Cable-Controlled Quick Detach (QD) Standard	Cable-Controlled Quick Detach (QD)/Electronic Controls (XTC) Standard	Cable-Controlled Hydraulic Remotes Standard	
Maximum Reach, Horizontal (A)	14' 1"	16' 5"	18' 1"	11' 5"
Maximum Height, Horizontal (B)	13' 2"	14' 6"	16' 1"	7' 2"
Maximum Height, Horizontal (C)	13' 5"	15' 9"	17' 5"	5' 7"
Maximum Height, Vertical (D)	13' 9"	20' 8"	22' 4"	10' 2"
Maximum Depth, 45°	5' 4"	7' 3"	8' 2"	4' 6"
Lightbar Kit	Standard			

* RMB1445-1, RMB1660-1 and RMB1865-1 include weight of oil.

HEAD SELECTION CHART

MODELS: RMB1445-1 | RMB1660-1 | RMB1865-1 | PT5 Powertrim-2

FLAIL HEAD	Minimum Tractor PTO HP/Weight	45 / 4,410 lb.	60 / 6,614 lb.	65 / 7,716 lb.	Not Available For Use On This Model
	Rotor/Knife	Super Cut/ Universal	Super Cut/F91 Competition or Multi-Cut Competition		NA
	Typical Application	Grass, Light Brush	Hedge Cutting, Grass		NA
	Cutting Capacity	1" Diameter	1½" Diameter	2" Diameter	NA
	Cutting Width	39"	47"		NA
ROTARY HEAD	Minimum Tractor PTO HP/Weight	Not Available For Use On This Model	85 / 7,614 lb.	85 / 8,716 lb.	Not Available For Use On This Model
	Typical Application	NA	Grass/Brush		NA
	Cutting Capacity	NA	4" Diameter		NA
	Cutting Width	NA	60"		NA
CUTTER BAR	Minimum Tractor PTO HP/Weight	45 / 4,410 lb.	60 / 6,614 lb.	65 / 7,716 lb.	15 / 1,212 lb.
	Cutter Type	Sickle Bar			
	Cutting Capacity	1 ¼" Diameter			¾" Diameter
	Cutting Width	59"			

FORWARD REACH REAR-MOUNTED BOOM MOWER SPECIFICATIONS

MODELS: RMB1880F | RMB2080F

Minimum Tractor PTO HP	80	
Tractor Minimum Weight (lb.)	8,818	
Tractor PTO	540	
Machine Weight (lb.)*	2,469	2,540
Hydraulic System	Totally Independent	
Attachment Method	Cat 2 & 3, 3-Point Mount	
Controls	Two-Way Rotor Engagement - Electric Control (ERC)	
Maximum Reach, Horizontal (A)	18' 1"	19' 8"
Maximum Height, Horizontal (B)	16' 1"	17' 9"
Maximum Height, Horizontal (C)	17' 5"	18' 8"
Maximum Height, Vertical (D)	22' 0"	23' 4"
Maximum Depth, 45°	7' 10"	9' 2"
Lightbar Kit	Standard	

* Excluding attachment and oil

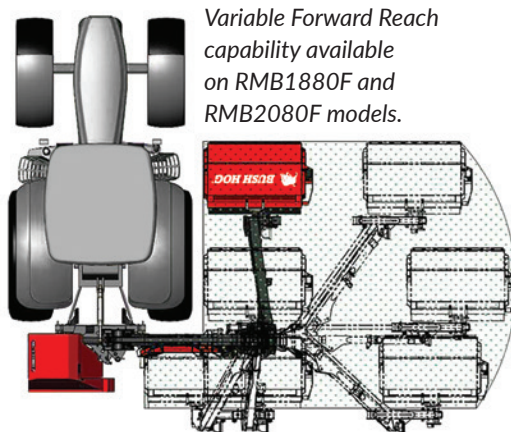

Variable Forward Reach capability available on RMB1880F and RMB2080F models.

HEAD SELECTION CHART

FLAIL HEAD MODELS: 50081485 | 50081486 | 50081487

Minimum Tractor PTO HP / Weight	80 / 8,818 lb.		
Rotor / Knife	Uni-Boot Flail	Omega Flail	Uni-Boot Flail
Typical Application	Hedge Cutting, Grass		
Cutting Capacity	1" Diameter	1½" Diameter	1" Diameter
Cutting Width	47"	45"	59"

ROTARY HEAD MODELS: 50081488

Minimum Tractor PTO HP / Weight	80 / 8,818 lb.
Typical Application	Grass / Brush
Cutting Capacity	4" Diameter
Cutting Width	47"
Cutting Width	47"

* Excluding attachment and oil