

COMBINE HEADERS

MacDon®



GET MORE

| D2/FD2

Durability. Capacity. Speed. MacDon's 2 Series Combine Headers deliver all the latest performance and innovation that MacDon offers. The D2 Draper and FD2 FlexDraper® boast an all-new frame that features a super structured five-sided backtube. This solid backbone is ready to handle up to 20% increased capacity* from an ultra-deep 50-inch draper deck†. And that deeper draper gets filled up a lot quicker thanks to MacDon's ClearCut™ High-Speed Cutting System. Wrap it all up with MacDon's rock-solid reliability, and it's clear to see how MacDon 2 Series Combine Headers get you more from every acre.

* Compared to the previous model.

† 127 cm (50")

** Some products or options may not be available in all markets.
Find your local dealer at MacDon.com





SCAN HERE



D2 WEBSITE



FD2 WEBSITE

Active Float System

The D2 and FD2 get instant float response with MacDon's Active Float System. Integrated but independent of the combine's auto header height control, this simple mechanical system supports up to 97% of the header's weight, allowing the 2 Series Combine Headers to float over ground fluctuations effortlessly. In addition, this instant float response lets the header cut close to the ground without pushing dirt, delivering a clean, close, even cut every time.



*Supports up to **97%** of header's weight*

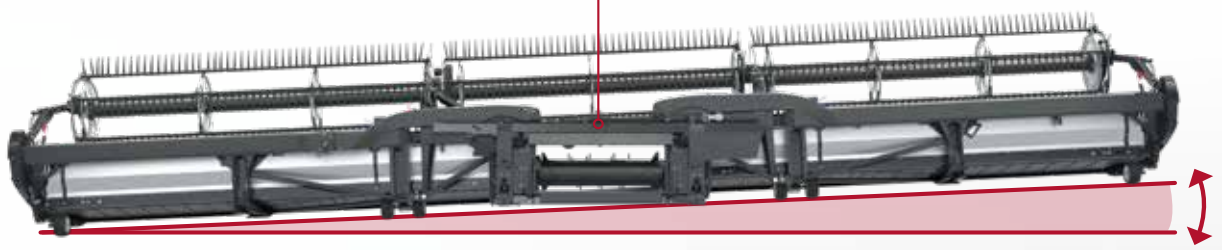

A ClearCut™ Knife Sections

MacDon ClearCut™ knife sections feature over 25% more cutting surface thanks to a longer blade and improved geometry. So what does that mean for you? It means faster, cleaner cut quality at higher ground speeds.

Stay Sharp!

Another great advantage of this new cutting system is the redesigned hardware. Fitted bolts make in-field knife section replacement quick and easy.

B ClearCut™ Pointed Knife Guards

ClearCut™ Pointed Knife Guards are multi-purpose knife guards designed to glide along the surface at high cutting speeds for a clean, even cut every time.

ClearCut™ PlugFree™ Knife Guards

This guard design gets the knife as close to the ground as possible while still protecting the blade from damaging debris in the field. ClearCut™ PlugFree Knife Guards resist plugging even in the nastiest conditions providing the closest, cleanest possible shave of the ground.

C ClearCut™ High-Speed Knife Drive

MacDon's improved knife drive satisfies your need for speed, providing more torque to power through the most challenging cutting conditions. Featuring a larger output shaft, a flywheel for smooth operation, and a direct hydraulic drive, it's the heart of MacDon's ClearCut™ High-Speed Cutting System.

D ClearCut™ High-Speed Cutting System

MacDon's ClearCut™ High-Speed Cutting System delivers clean cutting at up to 30% faster speeds*. This high-speed system is delivered with two unique knife guards, more power from MacDon's improved knife drive and over 25% more cutting surface from an increased knife and guard geometry. Altogether, these improvements allow 2 Series Combine Headers to provide a smooth, clean, even cut every time.

* Compared to the previous model.

A

**OVER
25%
MORE
CUTTING
SURFACE**



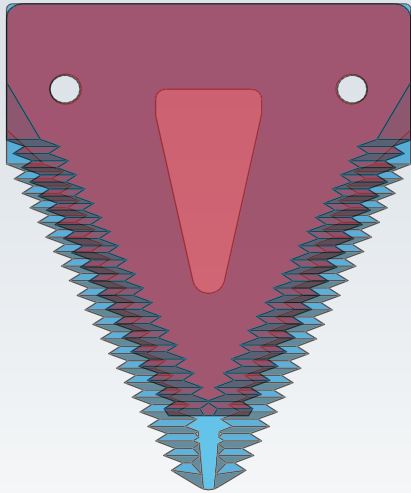

■ FD1 ■ FD2

B

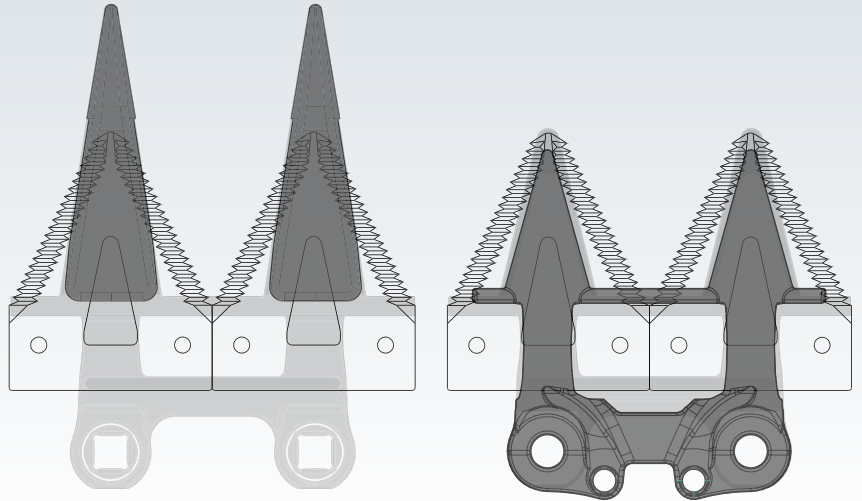

ClearCut™ Pointed
Knife Guards

ClearCut™ PlugFree™
Knife Guards

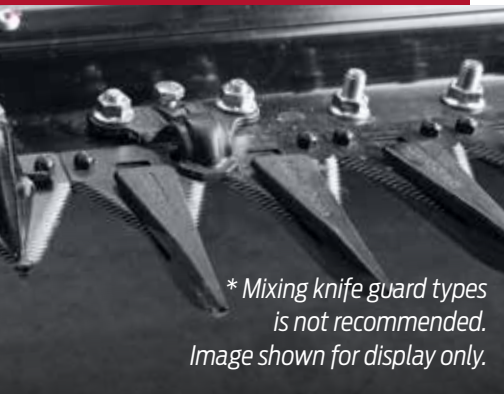

** Mixing knife guard types
is not recommended.
Image shown for display only.*

C



**30%
MORE
SPEED**



Any Combine

The 2 Series fits all major brand combines* with a completion package that integrates seamlessly with your combine for the best possible user experience. This multi-brand compatibility and interchangeability mean your investment will hold its value when you decide to upgrade.

** See your MacDon Dealer and find out if the 2 Series will fit your combine.*



Super-Sized Capacity

With today's modern combines, it's all about more capacity, and with the 2 Series, you get up to 20%* more of it. This serious capacity boost comes from an ultra-deep deck featuring 50-inch deep drapers. These huge drapers perform with ease, cleanly laying down the biggest bushiest high-volume crops, keeping those big combines running smoothly with consistent heads-first feeding. This deeper draper also provides improved cutterbar visibility from the combine.

New for the FD2 is a 50-foot header size; paired with the deeper draper deck, the FD250 delivers the most crop capacity ever offered in a FlexDraper® model*.

** Compared to the previous model.*

+ 127 cm (50"), 15.2 m (50')



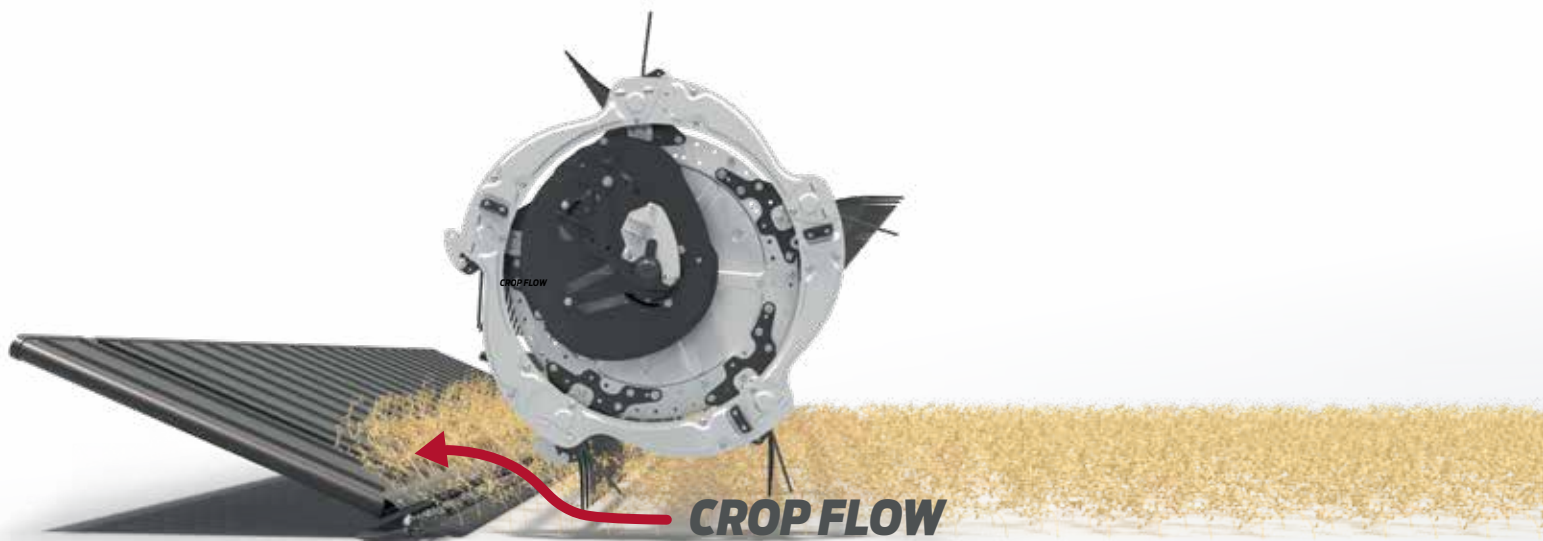

Amazing Reel Performance

The unique movement of the 2 Series reel picks up and gently places crop onto the drapers. Our cam design allows the reel fingers to get underneath lodged crop and pick it up before cutting. Aluminum reel ends and sectors help reduce overall weight and improve efficiency. The 2 Series header and reel are highly adjustable right from the cab for optimal performance. Header tilt control adjusting the draper and knife angle, and fore-aft reel positioning lets you set up for the most challenging real-world harvesting conditions.





FeedMax™ Crop Feeding System

Big, small, new, old, the FeedMax™ Crop Feeding System has an aggressive feeding action and can be custom configured to match any combine's performance. Featuring combine-tailored speed control and customizable auger flighting to fit any combine's feeder house opening, the FeedMax Crop Feeding System upgrades and optimizes any combine's performance.

FeedMaX™



**HEADS-FIRST FEEDING LETS YOU
START EARLIER AND END LATER**

Heads-First Active Crop Flow

Once the crop gets on the drapers, MacDon's Active Crop Flow takes over, swiftly moving the crop heads-first down the side drapers and into the combine's feeder house. Now standard on the 2 Series, the in-cab side draper speed control allows on-the-go adjustment. Heads-first feeding promotes peak combine efficiency by improving threshing action, creating better straw distribution, and providing an overall more productive fuel-saving harvest. What's more, MacDon's Active Crop Flow is more efficient in damp and moist conditions, meaning you can start earlier and work later into the evening.

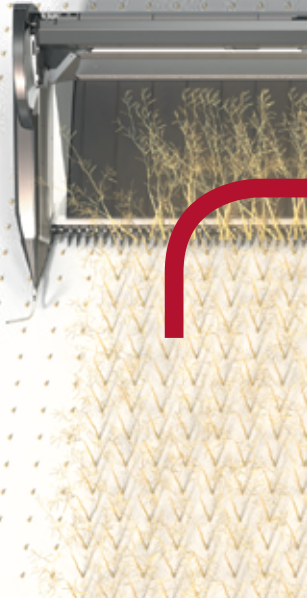



Full-Length Upper Cross Auger

A performance option worth considering for anyone harvesting big bushy, high-volume crops, like canola, oilseed rape, peas, and mustard, is the Upper Cross Auger. The auger keeps bushy crops on the draper as they move to the center of the header, where twin pitch flighting actively and aggressively drives the crop down onto the feed auger. This option runs the entire length of the header and is available in all sizes.

HEADS-FIRST FEEDING INTO COMBINE

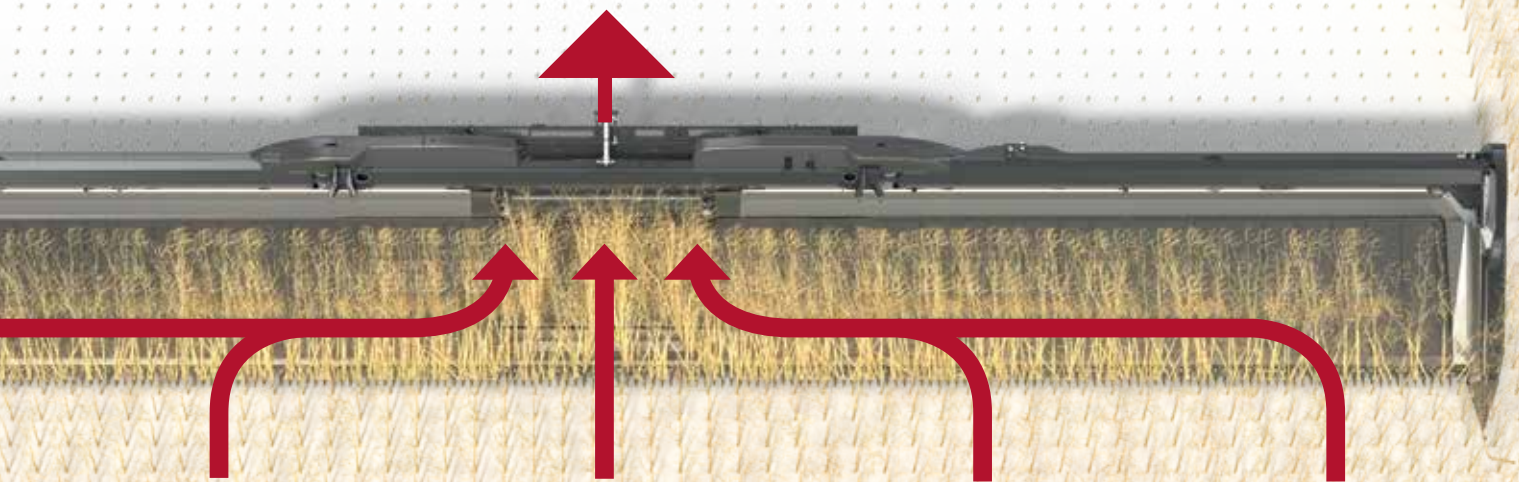

CROP FLOW

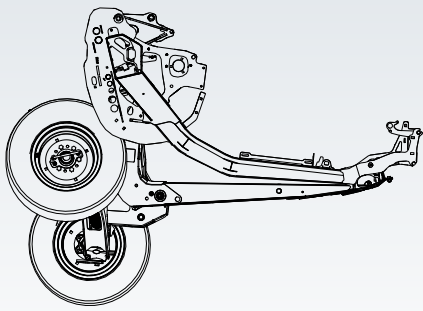

IN-FIELD

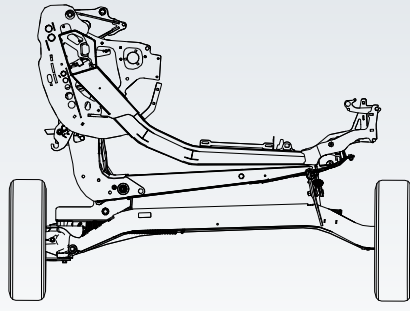

ON ROAD

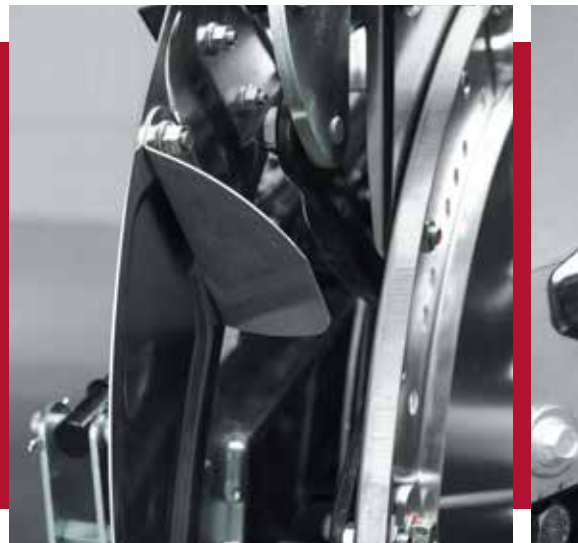



A Aluminum Components

From a glance, the most noticeable design cue on the 2 Series is the addition of aluminum components. Aluminum features include reel endshields, reel sectors, and backsheets. But these components aren't just for looking good; they help reduce the overall weight of the header, improving efficiency without compromising strength.

B Easy Adjustments

You'll be ready to go as soon as the crop is with the 2 Series' easy adjustments.

Easy adjustments include:

- Easy to follow decals and adjustments to set the float (D2 & FD2) and flex (FD2 only).
- Easy access to the reel drive chain tensioner; just flip off the cover and use the Set-It-Right Multi-Tool to adjust.
- Now standard, in-cab on-the-go side draper speed control.
- Easily switch from flex to a rigid frame header with the flip of a lever (FD2 FlexDraper).
- Quick Latch End Divider System allows you to hook and connect your divider in one move.



C EasyMove™ Transport*

MacDon's EasyMove™ Transport System makes it faster than ever to move your 2 Series Combine Header from field to field. This Performance Option is entirely self-contained on the header and allows transport at speeds up to 32 km/h (20 mph)**. Machines equipped with this option can also use the transport wheels in-field to stabilize the header.

** Some products and/or options may not be available in all markets.*

See your MacDon Dealer for availability.

*** Always follow local traffic laws and regulations.*



D Clean Sweep Crop Keeper System

MacDon added a bunch of little extras onto each 2 Series Combine Header to keep the crop moving in the right direction, into the combine and onto your bottom line.

The Clean Sweep Crop Keeper System includes:

- Angled reel fingers and tines on the reel ends.
- Reel endshield crop paddles.
- Reel endshield crop deflectors.
- Inner endshield crop deflector fingers.



ShatterGuard Reel Positioning

Using MacDon's Set-It-Right Multi-Tool, this quick, simple adjustment to the reel comes standard on all 2 Series models. ShatterGuard Reel Positioning is designed for tall brittle bushy crops like canola and oilseed rape. This adjustment sets the reel further back on the header, preventing shatter on the ground and keeping the crop on the drapers where you want it.



Set-It-Right Multi-Tool

Conveniently stored onboard the header, the Set-It-Right Multi-Tool is all you need to get the 2 Series dialed in for harvesting success.

The Set-It-Right Multi-Tool lets you make the following adjustments:

- Set and adjust the header float (D2 & FD2) and flex (FD2 only).
- Set the ShatterGuard reel positioning.
- Adjust the reel finger positioning and reel drive chain tension.
- Add and remove end divider cones.



A Consistently Close Shave

MacDon's low-profile cutterbar improves on an already good thing; the knife's distance to the draper is shorter, meaning less chance of seed loss at the cutterbar. In addition, in-cab header tilt control adjusts the knife angle to match any harvest condition, and the ultra-smooth ground-facing surface of the cutterbar helps it glide along the ground for a smooth close shave every time.



Durability

MacDon has always ensured reliability by engineering rock-solid products, and the 2 Series carries that tradition forward. The 2 Series boasts a new frame featuring a super structured five-sided back tube. This solid backbone is ready to handle the up to 20% increased capacity* of the ultra-deep 50-inch+ draper deck.

** Compared to previous model.*

+ 127 cm (50")

SPECIFICATIONS

D2 DRAPER HEADER SPECIFICATIONS

Size*	7.6 m (25')	9.1 m (30')	10.6 m (35')	12.5 m (41')	13.7 m (45')
Weight** Single Knife Drive without FM200	2120 kg (4672 lb)	2484 kg (5475 lb)	2706 kg (5963 lb)	-	-
Weight** Double Knife Drive without FM200	-	-	-	3006 kg (6626 lb)	3127 kg (6893 lb)
Knife: Type / Drive / Speed	Single or Double knife / Hydraulic, MacDon design enclosed oil bath knife drive box(es) / 1200-1400/1500 spm, varies depending on header size				
Guard Types Available	ClearCut™ Pointed Guards - Forged and Double Heat Treated (DHT) with Forged, Single Bolt Adjustment Hold-Down; ClearCut™ PlugFree™ Short Guards - Forged and Double Heat Treated (DHT) with Forged, Dual Bolt Adjustment Hold-Down				
Reel: Type / Drive / Speed / Fingers	Pick-up Reel, six bats, one-piece (single) or two-piece (double), flip-over design, cam-leading finger control / Hydraulic / 0 to 67 rpm (varies depending on combine model) / 290 mm (11.4") length, wear-resistant HD plastic, 102 mm (4") spacing				
Conveyor: Type / Drive / Speed / Delivery	1270 mm [50"] / Hydraulic / FM200 (Combine Float Module) - 0 - 209 m/min [687 ft/min] / 15' (on SP Windrower) -1395 - 1525 mm [54.9" - 60.0"]				
Field-Installed Options	EasyMove™ Transport System, Upper Cross Auger, VertiBlade™ Vertical Knife, stabilizer wheels, lateral tilt automatic header height control, Sunflower attachment				

* Product size availability varies by market ** All listed weights are approximations and will vary depending on header configuration. Check with your dealer for combine ratings.

FD2 FLEXDRAPER® SPECIFICATIONS

Size*	7.6 m (25')	9.1 m (30')	10.6 m (35')	12.2 m (40')	12.5 m (41')	13.7 m (45')	15.2 m (50')
Weight** Single Knife Drive without FM200	2276 kg (5016 lb)	2655 kg (5851 lb)	2863 kg (6311 lb)	2947 kg (6495 lb)	-	-	-
Weight** Double Knife Drive without FM200	-	-	2943 kg (6487 lb)	3063 kg (6759 lb)	3238 kg (7136 lb)	-	-
Weight ** Double Knife Drive with Triple Reel without FM200	-	-	-	3212 kg (7079 lb)	-	3590 kg (7912 lb)	3803 kg (8382 lb)
Knife: Type / Drive / Speed	Single or Double knife / Hydraulic, MacDon design enclosed oil bath knife drive box(es) / 1200-1400/1500 spm, varies depending on header size						
Guard Types Available	ClearCut™ Pointed Guards - Forged and Double Heat Treated (DHT) with Forged, Single Bolt Adjustment Hold-Down; ClearCut™ PlugFree™ Short Guards - Forged and Double Heat Treated (DHT) with Forged, Dual Bolt Adjustment Hold-Down						
Reel: Type / Drive / Speed / Fingers	Pick-up reel, five bats, one-piece (single), two-piece (double) or three-piece (triple), flip-over design, cam-leading finger control / Hydraulic / 0 to 67 rpm (varies depending on combine model) / 290 mm (11.4") length, wear-resistant HD plastic, 102 mm (4") spacing						
Conveyor: Type / Drive / Speed	1270 mm (50") deep, reversible, rubber skim-coated drapers, double V-guide with tracking, integral seal on leading edge / 0 to 209 m/min (0 to 687 ft/min)						
Standard Features	Fits most current model combines, hydraulic fore-aft reel positioner, hydraulic header tilt, in-cab side draper speed control, cutterbar poly wear plates, auto-header height with header angle and ground pressure indicators						
Field-Installed Options	EasyMove™ Transport System, ContourMax™ Contour Wheels, Upper Cross Auger, VertiBlade™ Vertical Knife, stabilizer wheels, lateral tilt automatic header height control, Sunflower attachment						

* Product size availability varies by market. ** All listed weights are approximations and will vary depending on options installed. Check with your dealer for combine ratings.

FM200 FLOAT MODULE SPECIFICATIONS

	Center Draper	Feed Auger
Weight	Approximately 1083 – 1171 kg (2387 – 2581 lb), varies by combine configuration	
Size	2000 mm (78.7") width	1630 mm (64.1") width
Type	Hydraulic drive (reversible), self tracking rubber coated polyester fabric feed draper with rubber slats	Mechanical drive (reversible), removable retracting fingers with bolt on fighting
Speed	107-122 m/min (350-400 ft/min), varies with combine brand	191 - 195 rpm, varies with combine brand
Header Floatation: Type/ Vertical Range/Lateral Range (Tilt)	2 pairs of coil springs, independent adjustment, transport lock-out / 178 mm (7") / 4.8 degrees	