

# C314

MINI TRACK LOADER





# Take a break from back-breaking work.

Ditch the shovel and wheelbarrow and all the hard manual labor that goes with them. The **New Holland C314 mini track loader** is all the equipment you need to get more done. The C314's big operating capacity adds more jobs to your residential construction and landscaping checklist. And its narrow working width gets you in and out of tight spots with ease.

**Power and versatility are a formidable combination in a C314:**

- **1,000 lbs. of rated operating capacity**—easily handles lift-and-carry operations
- **Common industry interface and 14-pin electric multifunction control**—offers greater versatility with new and older attachments
- **Wide range of attachments**—power New Holland augers, trenchers, grapple buckets, rakes, and more



## OPERATING WEIGHT

Narrow Track (NT)	2X Counterweights (STD): 3,536 lb (1 604 kg)
Wide Track (WT)	6X Counterweight (OPT): 3,783 lb (1 716 kg)

## DIMENSIONS

Overall Height	56.5 in (1 435 mm)
Overall Length: Without Bucket	85.6 in (2 175 mm)
Machine Width:	
Narrow Track	35.0 in (890 mm)
Wide Track	40.4 in (1 026 mm)
Bucket Width:	
Narrow Track	36.0 in (914 mm)
Wide Track	42.0 in (1 067 mm)

## LOADER PERFORMANCE SPECS

Lift Geometry	Radial Lift
<b>Narrow Track Rated operating capacity – ROC*:</b>	
35% of tipping load	992 lb (450 kg)
50% of tipping load	1,416 lb (643 kg)
Narrow Track Tipping load*	2,833 lb (1 285 kg)
<b>Wide Track Rated operating capacity – ROC*:</b>	
35% of tipping load	1,102 lb (500 kg)
50% of tipping load	1,574 lb (714 kg)
Wide Track Tipping load*	3,148 lb (1 428 kg)

NOTE: Measured using standard equip bucket.

## ENGINE

Model	Kubota D1305-E4B
Emissions Certification	Stage V
Cylinders	3
Displacement	77.0 in <sup>3</sup> (1.261 L)
Fuel	Diesel
Exhaust aftertreatment	N/A
Engine speeds Rated – full load	RPM 2600

## Horsepower @ 2600 RPM – SAE J1349:

Gross	24.8 hp (18.5 kW)
Net	24 hp (18.0 kW)
Peak torque @ 1700 RPM	59.1 lb-ft (80.1 N-m)

## DRIVETRAIN

Transmission Type	Hydrostatic
Max. Travel speed	4.7 mph (7.5 kph)
Parking brake: Type	SAHR pin brake

## ELECTRICAL

System Voltage	12 Volts
Alternator	60 amp
Battery	62 AHR 540 cold-cranking amps @ 0° F (-18° C)

## HYDRAULICS

Implement pump type	Fixed Gear
Displacement	1.2 in <sup>3</sup> (19 cm <sup>3</sup> )
Standard flow @ rated engine RPM: @ 100% efficiency	13.2 gpm (50 L/min)
Loader control valve: Type	Open center
Implement Hydraulics Operating Pressure:	2,800 psi (190 bar)

## SERVICE CAPACITIES

Fuel Tank	7.9 gal (30 L)
Engine oil w/ filter	6.0 qt (5.7 L)
Hydraulic system	4.5 gal (17 L)
Engine Coolant	0.9 gal (3.5 L)



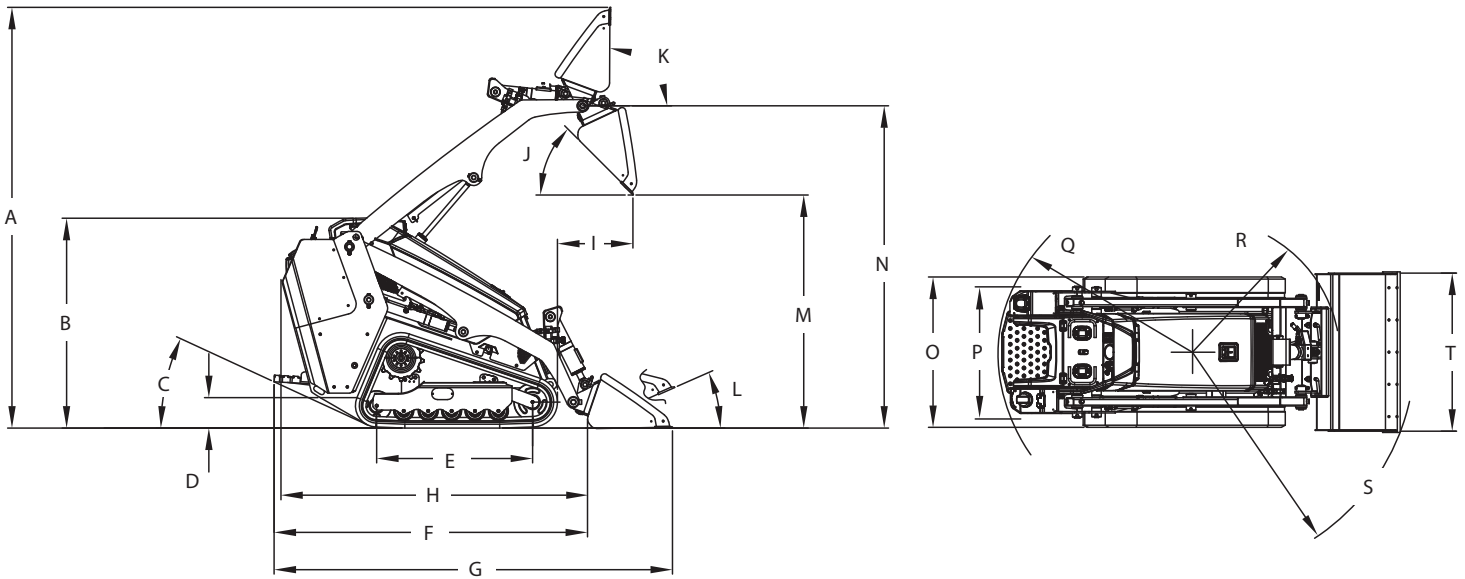

Line drawings are for illustrative purpose only and may not be exact representation of unit.

#### DIMENSIONS

A	Overall operating height	114.6 in [2 911 mm]
B	Overall height	56.5 in [1 435 mm]
C	Rear departure angle	24°
D	Ground clearance	8.7 in [222 mm]
E	Track length on ground	41.9 in [1 065 mm]

#### Overall length:

F	without bucket	85.6 in [2 175 mm]
G	with standard bucket	110.1 in [2 796 mm]
H	Transport Length – no bucket, platform raised	85 in [2 155 mm]
I	Reach at Maximum Dump	20.1 in [511 mm]
J	Dump angle	48°
K	Maximum rollback at full height	90°
L	Maximum rollback at ground	24°
M	Dump height – standard bucket	61.0 in [1 549 mm]
N	Hinge Pin Height	86.7 in [2 201 mm]
O	Machine width:	
	Narrow Track	35.0 in [890 mm]
	Wide Track	40.4 in [1 026 mm]
P	Track Gauge:	
	Narrow Track	28.0 in [710 mm]
	Wide Track	30.6 in [776 mm]

#### Clearance Circle Radius:

Q	Rear	53.1 in [1 348 mm]
R	No bucket	35.9 in [913 mm]
S	Standard bucket	60.7 in [1 541 mm]
T	Bucket Width:	
	Narrow Track	36.0 in [914 mm]
	Wide Track	42.0 in [1 067 mm]

#### TRACK SELECTION

Type	Area	Ground Pressure	Width to Outside Track
7 in [180 mm] – Narrow Track	594 in <sup>2</sup> [0.38 m <sup>2</sup> ]	5.9 psi [0.41 kg/cm <sup>2</sup> ]	35.0 in [890 mm]
10 in [250 mm] – Wide Track	825 in <sup>2</sup> [0.53 m <sup>2</sup> ]	4.6 psi [0.32 kg/cm <sup>2</sup> ]	40.4 in [1 026 mm]

## Standard Equipment

---

### Operator Environment

- Hydraulic pilot joystick control
- Loader and ground drive control lockout
- Cushioned operator platform
- Operator grab handles
- Key start
- Hand throttle
- Cup holder
- Pocket for cellular phone.

### Engine

- Engine tip-over shut-off
- Glow plug starting aid
- Locking fuel cap
- Fuel filter with water separator
- Electric fuel pump

### Drivetrain

- Dual hydrostatic drive motors
- SAHR parking brake
- 5 roller undercarriage
- Narrow rubber track belt

### Hydraulics

- 3-spool loader control valve
- 1x dual acting auxiliary hydraulics
- Proportional auxiliary hydraulic control on joystick with detent
- Loader arm float

### Loader

- Radial lift geometry
- CII mech attachment coupler
- Loader lift arm support strut
- 2x additional counterweight

### Electrical

- 12V power plug socket
- Front and rear LED work lights
- Master battery disconnect

### Other Standard Features

- Lock-able hood compartment
- Horn

### Telematics

- CASE SiteWatch™ Telematics – includes hardware and a 5-yr data subscription

### Warranty

- Base warranty coverage: 2-Year/2,000-hour full machine limited warranty

## Optional Equipment

---

### Drivetrain

- Wide rubber track belt

### Hydraulics

- Case drain attachment connection
- Bio-hydraulic oil and lubricants

### Loader

- 36 in dirt bucket
- 42 in dirt bucket
- Bolt on bucket teeth
- Bolt on bucket cutting edge
- 6x additional counterweights

### Electrical

- 14-pin electrical auxiliary connection

### Other

- English, Spanish, or French Operator Manual



New Holland Construction  
500 Diller Ave.  
New Holland, PA 17557

Learn more at [www.newholland.com](http://www.newholland.com)

Design, materials and/or specifications are subject to change without notice and without liability therefor. Specifications are applicable to units sold in Canada, the United States, its territories and possessions, and may vary outside these areas.

© 2023 CNH Industrial America LLC. All rights reserved. New Holland is a trademark registered in the United States and many other countries, owned by or licensed to CNH Industrial N.V., its subsidiaries or affiliates. Any trademarks referred to herein, in association with goods and/or services of companies, other than owned by or licensed to CNH Industrial N.V., its subsidiaries or affiliates, are the property of those respective companies.



Safety begins with a thorough understanding of the equipment. Always make sure you and your operators read the Operator's Manual before using the equipment. Pay close attention to all safety and operating decals and never operate machinery without all shields, protective devices and structures in place.

NHCXXXXXXXX • 0523 • OTP • PRINTED IN U.S.A.